

INSTALLATION AND OPERATING INSTRUCTIONS

RANGER GB GEAR REDUCTION UNIT

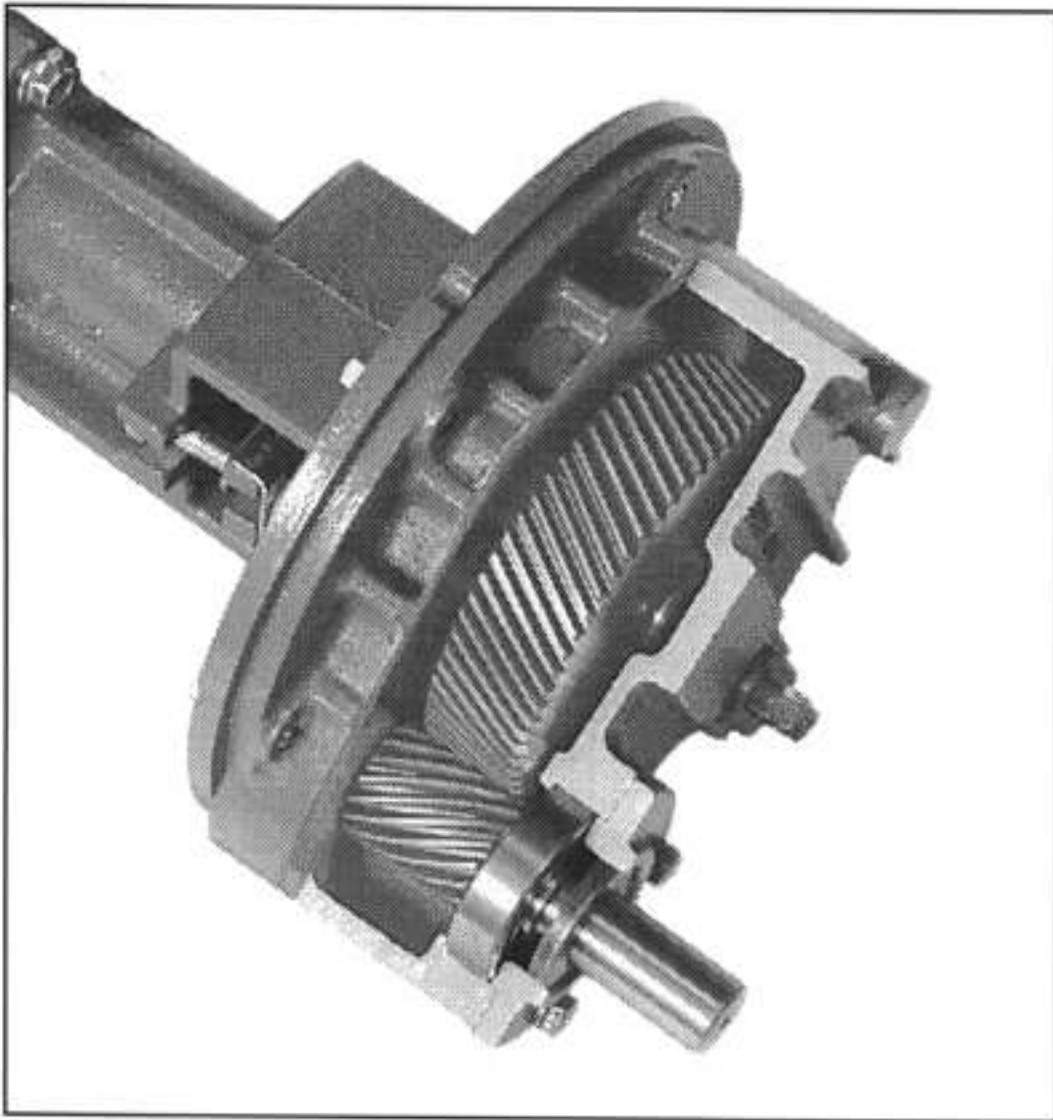

RANGER INC.

6400 Shelby View Dr., Suite 110

Memphis, TN 38134

Phone (800) 264-4115

Fax (901) 388-0470

GEAR REDUCTION OPERATION

Gear reduction units attached to the pumps as well as separate are not filled with gear lube. Ranger provides a bottle of gear lube with each gear box. Before starting pump, add part of the contents of the bottle to the gear box - to the open petcock (J). The oil level should be maintained to the petcock level. Note: Refer to assembly drawing for position of petcock, oil cup, and pipe plugs.

The input shaft of the gear reducer can be turned to any position within 360° . To change the position to match the motor shaft height loosen the six hex head cap screws (W) and rotate the gear case. If the input shaft cannot be moved to the correct position, remove the hex head cap screws (R) and rotate the input shaft to the correct position and reinstall the cap screws. In some cases it may be necessary to remove and rotate the cover plate (S) 90° to accommodate the correct positioning. Align the pump and motor coupling according to the coupling manufacturer's instructions. A periodic check of coupling alignment is required.

SERVICE INSTRUCTIONS

The gear lube should be clean and free from sludge and foreign matter and should be changed at regular intervals. To drain the gear lube, place a container under the pipe plug (L) and remove. It is suggested that you use Ranger gear lube to refill the unit, or you may substitute with an AGMA Grade No 7 compounded oil. It is recommended that the initial lube change be made after 50 hours of operation. Change lube every four months or 1000 hours, whichever comes first. If severe conditions exist such a rapid temperature, excessive dust or damp environment, change oil more often. The oil cup (K) functions as a filler cup and also as a breather for the gear box. Do not allow the filler cup to become clogged with foreign material.

TO DISASSEMBLE GEAR REDUCTION UNIT

1. Be certain that the driver is locked out to prevent starting of the pump accidentally.
2. Move the driver (motor/engine) and remove the coupling from the gear box input shaft.
3. Remove key (H) and hex head cap screws (A) and pry off bearing retainer (C).
4. Slide pinion shaft (I) out of gear case (M).
5. Remove hex head cap screws (W) and remove gear case cover (M).
6. Remove retaining ring (O) and pull off drive gear (P) off. (Drive gear may require removal with a gear puller.)
7. Examine parts for wear and replace as needed. To change gear ratio's use the same procedures to remove gears and replace with different ratio. The three ratio's available fit the same assembly. The number of teeth are different for each ratio, and must be replaced in pairs. The number of teeth is marked on the drive gear and marked on the end of the pinion shaft. (See Ranger Bulletin for ratio's available and additional information.)

TO ASSEMBLE GEAR REDUCTION UNIT

1. Place spacer (X) on shaft. (If it was removed)
2. Place drive key (DD) in pump shaft keyway. Install drive gear (P) on drive shaft (EE) and position in place with retaining ring (O).
3. Fasten gear case (M) to cover plate (S) including gasket (Q), using six cap screws (W). Be sure washers (U) and lock washers (V) are in place.
4. Press bearing (G) onto pinion shaft (I). Install retaining ring (F) onto pinion shaft. Including gaskets (D). Install pinion gear into gear case (M) by sliding pinion shaft into needle bearing (N) and mesh the gears together at the same time.
5. Slide bearing retainer (C) with the lip seal (E) installed into place. Use four cap screws (A) and washers (B) to secure retainer.
6. Install the key (H) to the gear box output shaft and assemble coupling and reconnect to the driver.
7. Refill gearbox with oil. Use Ranger furnished oil, or AGA No. 7 compounded oil.

TO REMOVE BALL BEARING FROM PUMP

1. The drive plate (CC) should be removed for the case (09). Note: Refer to Operation Manual, Page 13. After the drive gear (P) has been removed from the pump shaft, remove the key (DD) and spacer ring (BB). (The spacer ring is a slip fit and should come off easily.)
2. If the pump has a mechanical seal, remove the mechanical seal retainer plate (25) and locknuts (06). Note: Refer to Operation Manual, Page 13 and 15. Push against the drive plate end of the drive shaft (EE) to free and remove the ball bearing (Z). If the pump is packed box, the gland nuts (06) do not have to be removed to push the drive shaft free. Note: Refer to Operation Manual, Page 13.
3. Remove the bearing retainer (V) and the bearing (Z). Next remove the retainer ring (AA).
4. Use a flat screwdriver to remove the lip seal (BB) from the driveplate assembly.

TO INSTALL BALL BEARING IN DRIVE PLATE.

1. Press the lip seal (BB) into the driveplate assembly (CC).
2. Slide drive shaft (F) into the drive plate assembly (CC) and through the lip seal (BB). If the pump has a mechanical seal, install the seal as the drive shaft is installed. If the pump has packing, slide the drive shaft through the packing and packing gland. Further slide the drive shaft the lip seal to expose the retainer ring groove and install the retainer ring (AA). Slide the ball bearing (Z) up against the retainer ring (A). Install the retainer (V). Slide the spacer (X) on the drive shaft.
3. See instructions under, "to assemble gear reduction" to proceed further.

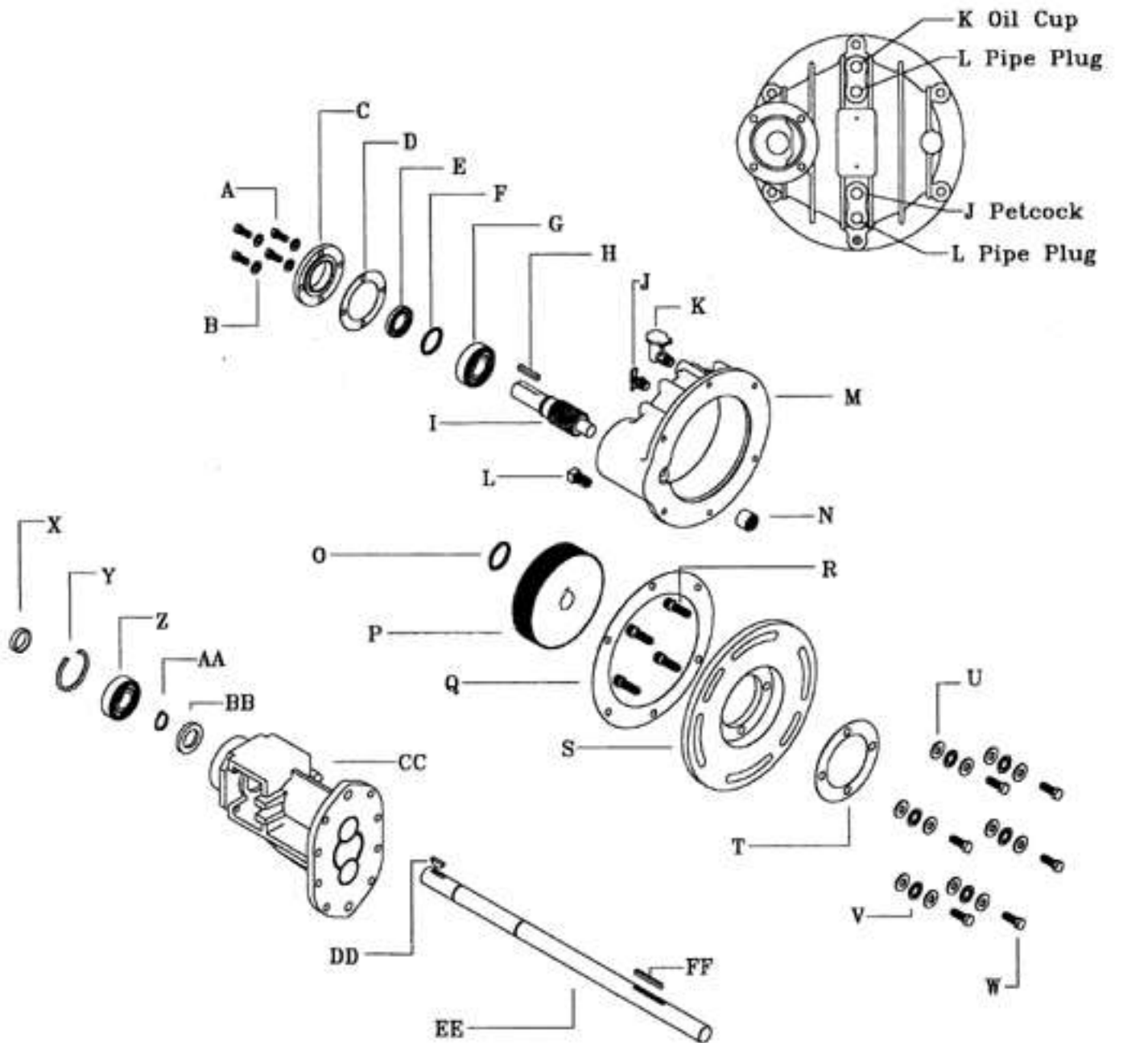

A	B60-312075	Hex Head Cap Screw	Q	210F-01U	GASKET
B	W01C-312	Lock Washer	R	B50-375125	Cap Screw
C	211I-01U	Bearing Retainer	S	207I-01U	Cover
D	240F-01U	Gasket	T	223F-01U	Gasket
E	258B-100175	Lip Seal	U	W00C-375	Washer
F	203C-118E	Retaining Ring	V	W01C-375	Lock Washer
G	204C-118244	Ball Bearing	W	B60-375125	Cap Screw
H	05C-252515	Key	X	55C-01G	Spacer
I	233C-32G	Pinion	Y	203C-106244	Retainer
J	73B-025NPT	Petcock	Z	204C-106244	Ball Bearing
K	74C-025NPT0502	Oil Cup	AA	203C-2501	Retainer
L	P40-025NPT	Pipe Plug	BB	56B-10683	Lip Seal
M	209I-01U	Gear Case	CC	12_-01G	Drive Plate Assem
N	204C-075100	Needle Bearing	DD	05C-2510	Woodruff Key
O	03C-106E	Retaining Ring	EE	31_-G	Shaft
P	234C-39G__	Drive Gear	FF	05C-252515	Key

WARNING

DO NOT DISCARD THIS MANUAL
READ INSTALLATION, OPERATION,
AND MAINTENANCE MANUAL
BEFORE INSTALLING, PERFORMING
MAINTENANCE, OR OPERATING A
RANGER PUMP.

ATTACH THIS MANUAL TO THE
PUMP IF YOU ARE INSTALLING
THE PUMP, BUT WILL NOT BE
THE OPERATOR.